



SAFETY THROUGH INNOVATION



CONTENTS

02

Why use Buildsafe?

03

The Orange Box

05

Temporary Fence

07

Perimeter Fallguard

09

Void Platform

11

Void Platform Stair System

13

Hang On Platform

15

Rafter Fallguard

17

Ground Up Fallguard

19

Aluminium Scaffolding

21

Lower Roof Walkway

23

Lower Roof Walkway Board

25

Buildcam

27

Balcony Fallguard

29

Internal Fallguard

31

Mobile Scaffold

33

Pool Platform

35

Unique Solutions

36

A word from the Directors

37

Locations

WHY USE BUILDSAFE?

TAILORED SOLUTIONS

At Buildsafe, we value health and safety above all. The very nature of the building industry is high risk, which is why Buildsafe seek to eliminate the risks associated with construction through innovative product design, engineering and smart working methods.

Buildsafe offers a holistic safety solution where you can be sure of a compliant build from the outset. An experienced Account Manager will work with you directly to tailor a complete solution to your needs. From fully designed and engineered products right through to our responsive operations team who are here to help you.

Buildsafe offers a complete range of unique and versatile products that have been designed with the user in mind. Our installers undergo extensive in-house and nationally recognised training so you can expect high attention to detail and high quality workmanship.

Understanding the ever increasing legislative demands placed on the industry, Buildsafe is committed to providing easily implemented client safety compliance solutions known as 'The Orange Box'. A complete set of document credentials so you can demonstrate a safe worksite and that you have chosen a reputable supplier.

What's in the box?

1. Third Party Engineer Certified

All products engineered to conform to Australian Standards and Third Party certified.

2. Complete set of Installation Manuals

Comprehensive installation manuals' identifying how each product is installed safely, and address engineer specifications to certify structurally sound.

3. Competent Installers

An experienced installation team at your service, all employees must undertake product specific training and assessment to be deemed a competent installer. Assessment is based on a three-tiered scale, measured on both experience and skill level.

4. Risk Assessment and High Risk Safe Work Method Procedures

Prior to every installation a site specific SWMS is prepared and risk assessment conducted to ensure the installation can be carried out safely and in accordance with our engineering standards.

5. Electronic Handover Certification

Once the job has been certified as fit for use by one of our senior installers, a detailed product specific audit is uploaded to our Client Portal for client viewing.

6. Client Audit Checklist

Transparency is important to us; with this in mind an installation checklist is available for you to audit preexisting installations for maintained structural integrity.

7. Quality Control

Complete quality control system in place, inspection processes and maintenance procedures in force to certify products are fit for use.

8. Innovation That Adds Value

Buildsafe invests in the development of practical solutions that improve safety, reduce rework and help projects run more efficiently. Our commitment to innovation ensures clients benefit from smarter ways of working as the industry evolves.

9. Technology Driven Oversight

We combine construction experience with modern technology to provide greater visibility, accountability and project control. Through solutions such as BuildCam, clients gain access to information that helps reduce risk, improve decision-making and protect profitability.

10. Client Portal Access

Providing greater transparency and visibility across your projects, Buildsafe's online client portal gives clients access to installation schedules, handover certifications and supporting documentation in one central location. Critical project information is available whenever and wherever it is needed.



Buildsafe gives you peace of mind knowing that every step of the way we have your edge protection safety compliance covered.

**BUILDSAFE.
SAFETY FIRST.**

TEMPORARY FENCE



TEMPORARY FENCE

The first step to creating a safe and secure site, Buildsafe's Temporary Fencing. Our fencing erects in minutes, is sturdy and durable.

Benefits include:

- Preventing unauthorised access.
- Minimising theft and vandalism.
- Keeping materials and debris on site.
- Meeting your obligations under OH&S legislation to ensure public safety.

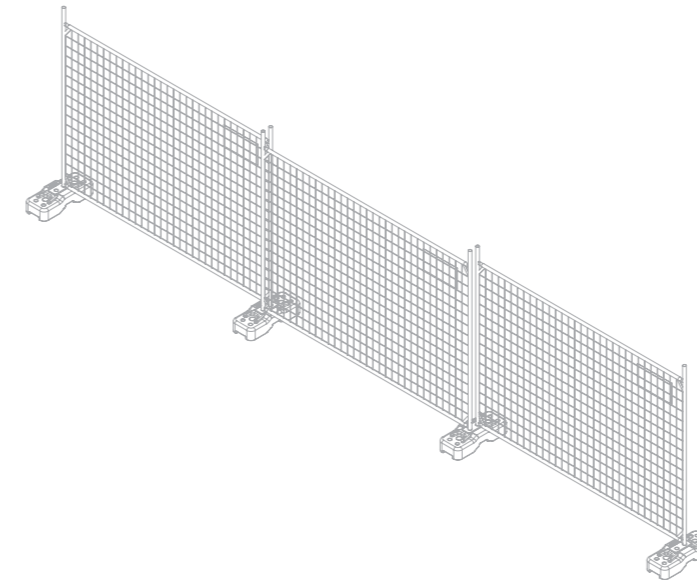

1. Buildsafe's innovative retaining wall clamp sits on top of the retaining wall, maximising space for tight areas.



2. Our retaining wall clamps offer a versatile attachment point which can be applied to many types of retaining walls.



3. Safe and secure site.



4. Buildsafe supplied custom gate locks provide peace of mind and greater security.

PERIMETER FALLGUARD



PERIMETER FALLGUARD

Builsafe's Perimeter Fallguard is installed pre-floorjoist, preventing falls and enabling tradesmen to work unobstructed whilst installing sheet flooring and upper level walls.

Benefits include:

- Meet OHS obligations concerning falls from heights.
- Superior flexibility and height safety throughout the construction process.

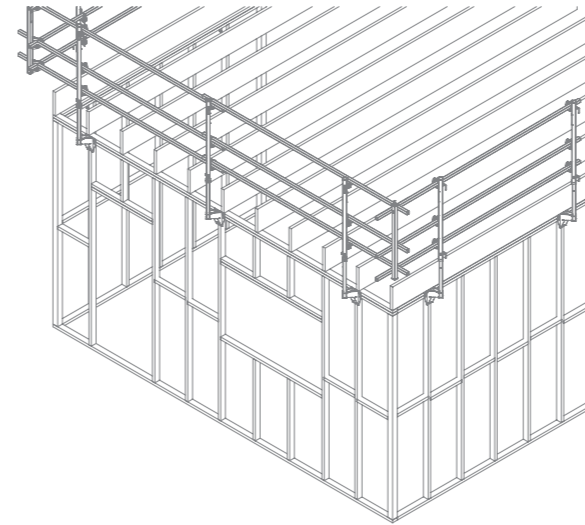

1. Allows for safe installation of the flooring.



2. Does not impede on site access or access inside the dwelling.



3. Allows for the safe installation of any upper level walls, it also provides room between the frame and rail for sheet bracing to be installed.



4. Brackets can be attached to both timber and metal frames.

VOID PLATFORM



VOID PLATFORM

Buildsafe's Void Platform® system turns an upper level void into a working platform and catch platform. This enables tradesmen to work on, around or above the platform safely.

Some features include:

- Custom fit to any size void opening.
- Complete engineered system which can be installed to timber, steel and masonry structural walls.
- Can be installed pre-floor installation.
- Compliant with Australian Standard AS/NZS 15761.

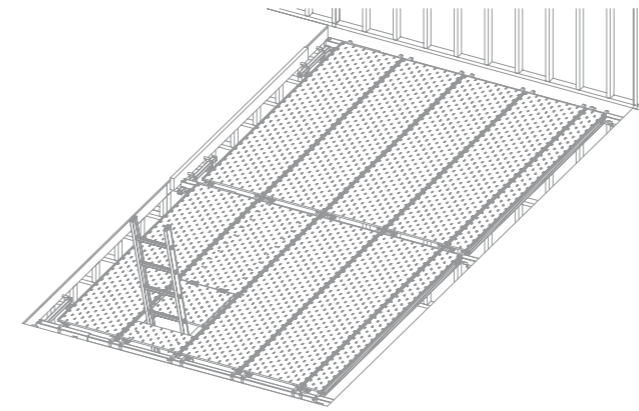

1. Acts as a catch platform for work being performed on or above the void opening.



2. No cut out required to the plasterboard at the attachment point, so no patch-up work required!.



3. Revolutionary roller system installed in conjunction with the material access hatch, making it easy to pass up bulky building material. The contoured roller has been designed to prevent damage whilst passing material such as plaster sheets to the second floor.



4. Our patented Ladder Bracket secures the ladder to the Void Platform® preventing it from slipping, whilst maintaining the required 4:1 pitch.

VOID PLATFORM STAIR SYSTEM



VOID PLATFORM STAIR SYSTEM

Builsafe have designed and engineered a universal stairway interconnected with a Void Platform cover for unrestricted access to the first floor. This is the first of its kind.

Benefits include:

- Installed at the earliest point of the construction process, providing a safe working environment for all tradesmen requiring access to the first floor.
- Improved efficiencies with passing bulky equipment through to the first floor with ease, whilst addressing manual handling.
- Can accommodate all stair configurations.

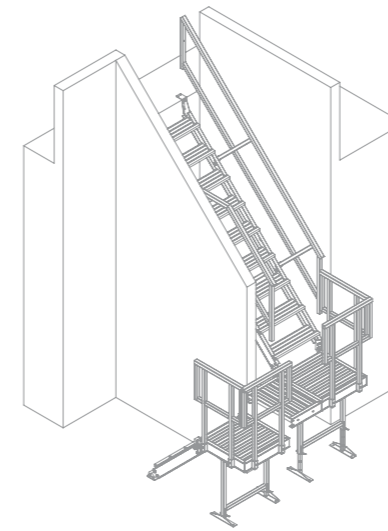

1. Enables safe access for tradesman with their tools and supplies, while eliminating strain of climbing up and down a ladder.



2. Stair system can be installed direct to floor when a platform isn't required. All Systems are freestanding sitting away from walls, allowing plaster to be completed.



3. System can easily be closed allowing trades to work on or above the void whilst temporary stairs remain in place.



4. Both access deck and material deck open.

HANG ON PLATFORM



HANG ON PLATFORM

Buildsafe's Hang On Platform offers unobstructed site access for tradesmen to complete fascia, gutter and roofing immediately after installation.

Benefits include:

- Faster build times by allowing trades earlier access to site.
- Can be installed pre-truss enabling trusses to be stood safely.
- Clear and clutter free building site.

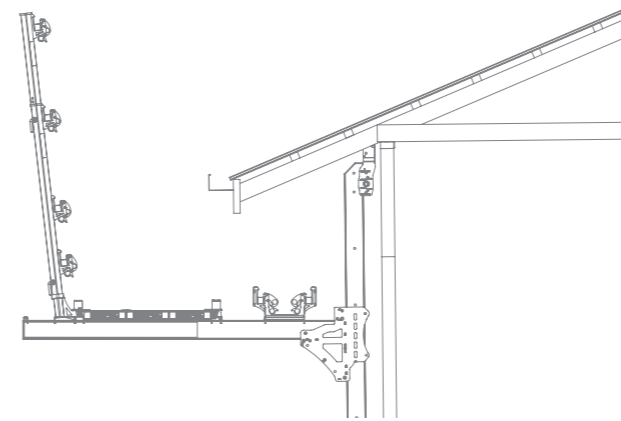

1. Additional stepped platform available to access roof surface.



2. Can be hung internally enabling lower roofs to be installed at the same time from the platform.



3. Pre-truss installation is available enabling trusses to be walked out and fixed from the hang on platform for safe installation.



4. Tiered access points installed for safe access to the platform.

RAFTER FALLGUARD



RAFTER FALLGUARD

Buidsafe's Rafter Fallguard system can be installed to a vast array of housing designs with a wide variety of brackets available to suit different construction methods.

Features include:

- The multitude of brackets and attachments available are all fully engineered for its intended purpose.
- Bright orange and yellow rail displays edge protection clearly in place.
- Low profile design allows us to safely secure under tile roofing.

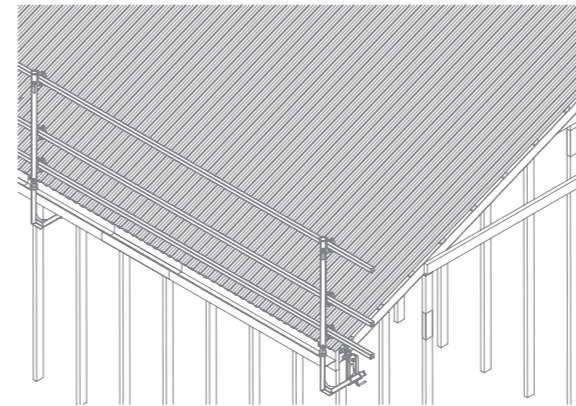

1. Engineered access gate.



2. Low profile under-tile connector allows brickwork and eaves to be completed without obstruction.



3. Non obtrusive toe board system available when required.
Can be attached to the rafter tail and returns around under the fascia and gutter for the installation of both tile and metal roof surfaces.



4. On sheet brackets are attached utilising existing screw holes on metal sheet roofing.

GROUND UP FALLGUARD



GROUND UP FALLGUARD

Builsafe's Ground-Up Fallguard system attaches to the outside of the wall, allowing tradesmen to complete work from behind the system safely.

Features include:

- Tradesmen can finish construction work including roof, box guttering, flashing and capping without the need to alter the system.
- No fixing point required, this enables the system to be used on almost any external finish including polystyrene cladding.

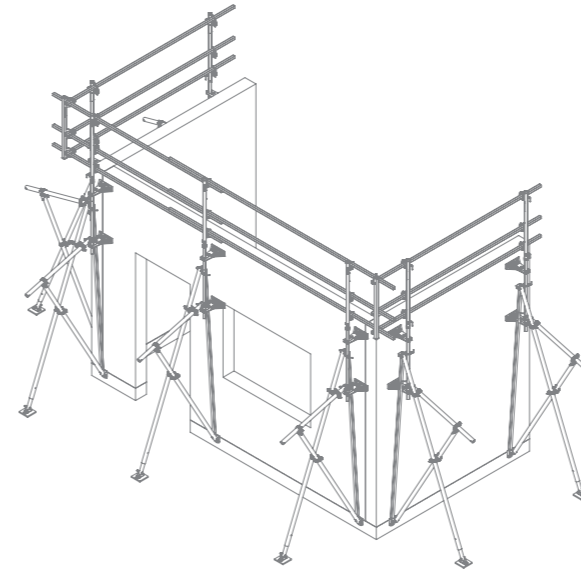

1. No patching up or repair work necessary once the job is complete.



2. No fixing required to face brick.



3. Perfect solution for zero eave guard rail requirements.



4. The unique design allows the installation of handrail where other suppliers would otherwise offer intrusive scaffolding.

ALUMINIUM SCAFFOLDING



ALUMINIUM SCAFFOLDING

Buidsafe's aluminium scaffolding is extremely versatile and much faster to install than the traditional steel scaffolding. Made from high quality lightweight material, yet strong and durable.

Benefits include:

- Makes erecting balconies quick and easy.
- Cost effective solution.
- Use for cladding, blue board, roofing, guttering, painting, rendering and edge protection.

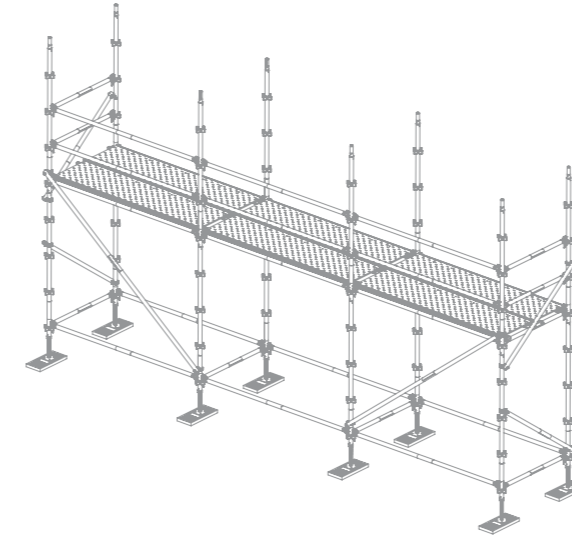

1. Can be used in conjunction with Buidsafe's Hang On Platform system, creating a continuous walkway around the dwelling.



2. Ideal for the safe lifting and securing of LVL beams and roof trusses to all types of balconies and portico's.



3. Can be utilised for the safe installation of roof trusses, fascia and gutter, along with providing compliant roof edge protection to all skillion style roofs.



4. Quick and simple results.

LOWER ROOF WALKWAY



LOWER ROOF WALKWAY

Buildsafe's Lower Roof Walkway system is the most versatile on roof walkway system on the market, reducing build time whilst preventing damage to roof sheets.

Features include:

- Can be adjusted to any height and pitch to suit any roof.

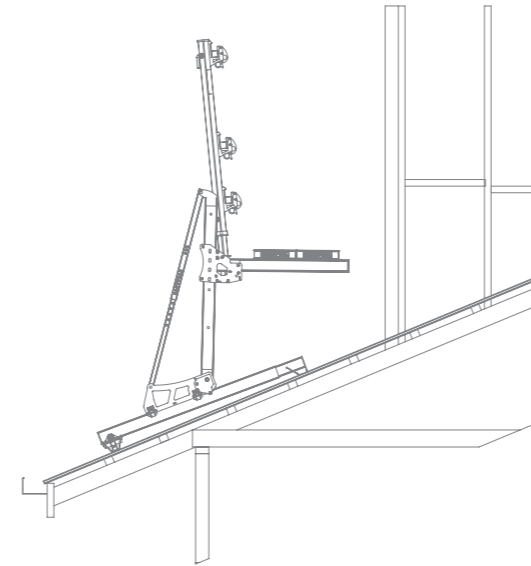

1. Secured to lower roofs, providing a safe level platform to work from, whilst providing protection to roof cladding.



2. Can be fitted to both tin or tiled roofs, or to trussed or battened roofs.



3. Designed to replace scaffold where a builder would conventionally run scaffold through the roof below, preventing work to be fully completed whilst product installed.



4. Specially designed system allows tradesmen to continue work with no disruption.

LOWER ROOF WALKWAY BOARD



LOWER ROOF WALKWAY BOARD

Builsafe's Lower Roof Walkway Board System provides a complete roof access and protection solution, creating safe, controlled movement from scaffold to roof and throughout designated work areas.

Features include:

- Safe and seamless transition from scaffold to roof access points.
- Defined walkways and work zones to improve site safety and efficiency.
- High-grip, non-slip surfaces.
- Protects roof finishes by distributing loads and reducing foot traffic damage.
- Designed for all trades including cladding, painting, roofing, and general external works.



- Seamless Scaffold to Roof Transition**
Provides a smooth transition from scaffold onto the roof platform, eliminating gaps and unsafe stepping points.



- Dedicated Walkway System**
Clearly defined access routes guide movement around the roof whilst preventing entry into unprotected areas and keeping trades within designated work zones.



- Non-slip Roof Protection**
High-grip, non-slip surface provides secure footing while improving confidence and stability underfoot and enhanced worker safety.



- Complete Edge Protection**
The system combines integrated walkways, edge protection, and barrier controls into one engineered platform.

BUILDCAM



BUILDCAM

Build smarter. Visit less. Know more.

BuildCam gives builders a verified record of what actually happened on site - without relying on phone calls, photos, drive-bys or guesswork. It captures site activity in 4K, detects meaningful events, and turns verified activity into a searchable record your supervisors, suppliers and management team can use to make faster decisions.

What it helps you do:

Reduce wasted site visits

- Supervisors can check progress, trades, deliveries and site activity before getting in the car.

Catch problems earlier

- Identify delays, missed trades, unsafe behaviour, unauthorised access and site issues before they become bigger problems.

Improve supplier coordination

- Suppliers can check site readiness before dispatching materials or trades, reducing wasted trips and follow-up calls.

Protect margin

- A verified site record helps reduce delays, theft, rework and disputes across the build.

A 'camera' records footage.
BuildCam records the build.



- 1. Capture**
BuildCam Secure films the site in 180° 4K, day and night.



- 2. Vera™ Verifies**
AI detects activity; the BuildCam audit team confirms what's real.

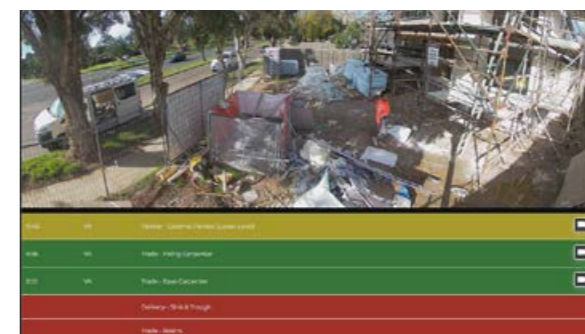

- 3. Sitetags™**
Verified records of trades, deliveries, inspections, safety, security and milestones.

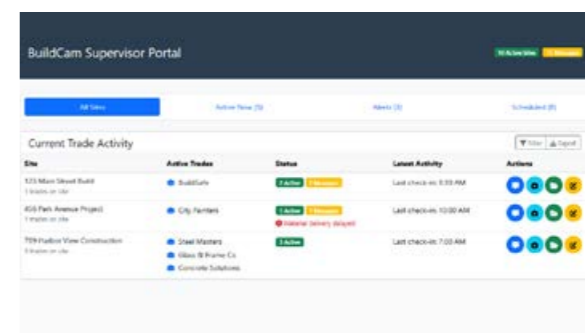

- 4. Put to Work**
Records flow into the portals, alerts and reports below.

BALCONY FALLGUARD



BALCONY FALLGUARD

Buidsafe's Balcony Fallguard is specifically designed to create a safe, unobstructed work area for all tradesmen. Our specially designed Clamp-On System enables edge protection to be applied at the finishing stages of construction and installed without drilling or screwing, so there is no patching required.

Benefits include:

- A range of brackets are available to suit a variety of balconies and facades.
- System engineered at 1500mm height to enable tradesmen to work on trestles compliantly.

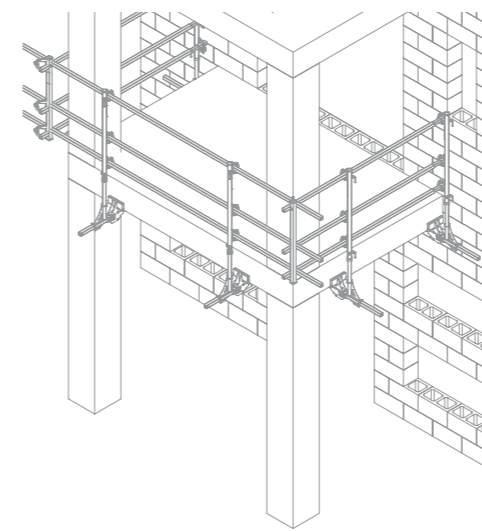

1. Allows tradesmen to complete waterproofing, tiles and balustrades prior to removal.



2. System can remain installed until after the finished balustrade has been fitted to the balcony.



3. No patch up work required.



4. Buidsafe's unique 'Clamp on System'.

INTERNAL FALLGUARD / SLIDING DOOR



INTERNAL FALLGUARD SLIDING DOOR

Buildsafe's Internal Fallguard and Sliding Door offer trade friendly solutions to suit any shape sliding door opening, window opening or stairwell.

Features include:

- Internal Fallguard Incorporates a gate for ladder access.
- No bolts, nails or screws required.
- Compliant with Australian Standard AS165791.

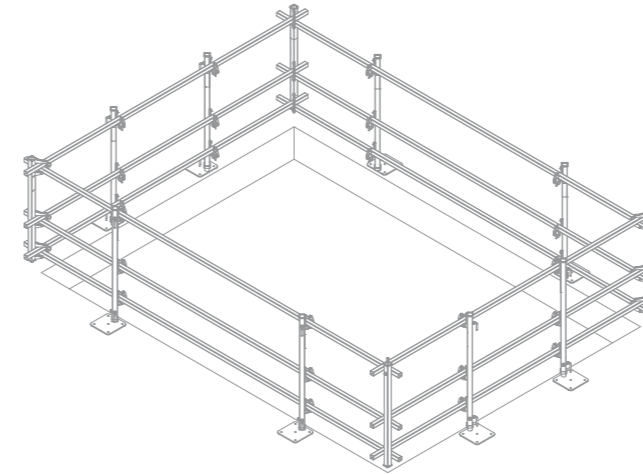

1. Restricted access to incomplete balcony.



2. Unobstructed edge protection for tradesmen.



3. Simple cost effective solution.

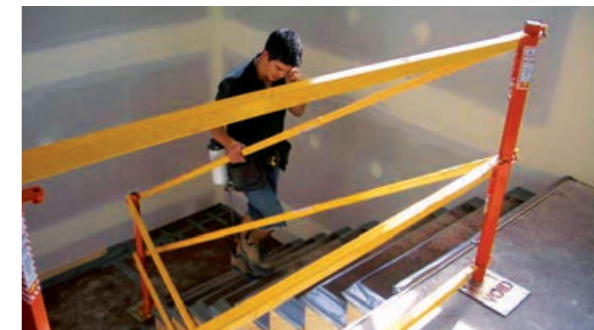

4. Versatile solution for all requirements.



MOBILE SCAFFOLD

MOBILE SCAFFOLD

Bulldsafe offers a comprehensive range of mobile scaffolding solutions that are stable and compact.

Benefits include:

- Easy to operate and maneuver.
- Access safety via ladder.
- Scaffold setup and dismantle service available.

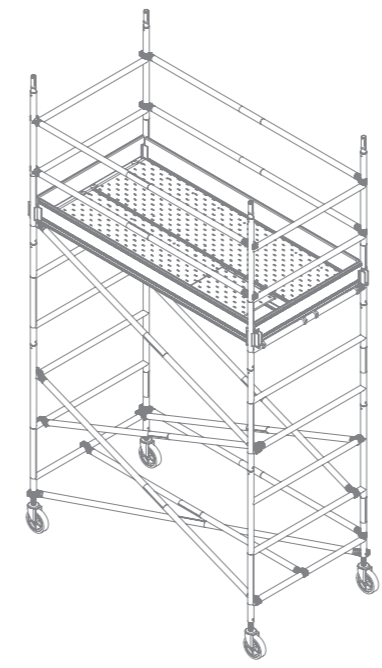

1. Safe solution for roof access.



2. 200mm locking castors for ease of mobility.



3. Variety of sizes available for all purposes.



4. Suitable for maintenance and restoration, installations and construction applications.

POOL PLATFORM



POOL PLATFORM

Builsafe Pool Platforms not only eliminate hazardous fallzones, they also create extra workspace on site. Rails are used to lock in the decks, enabling trades to work on the platform safely.

Benefits include:

- Simple and unobstructive way to protect persons on site.
- Custom fit to suit any site opening.
- Compliant with Australian Safety Standards.

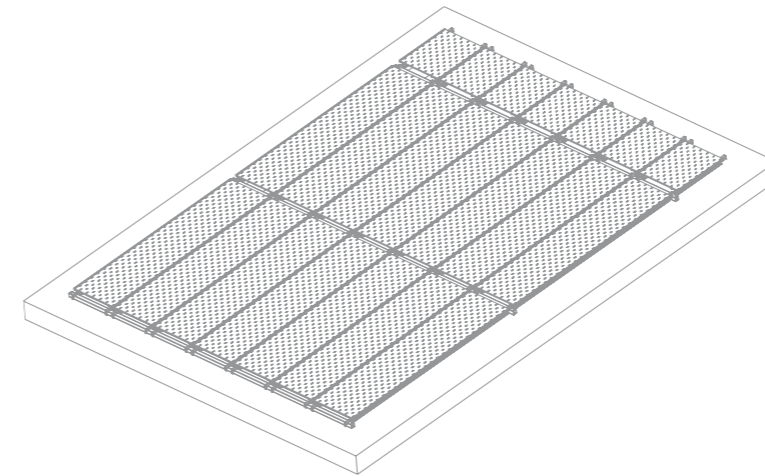

1. Engineered as a work platform.



2. Builsafe's temporary pool fence is ideal for preventing entry into potential fall zones.

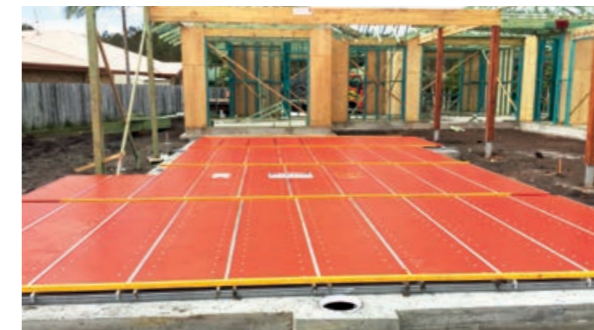

3. System is rated as a catch platform for work carried out during roof construction, offering a fall prevention system.



4. Creates extra space and a safe, stable working platform for the installation.

UNIQUE SOLUTIONS



UNIQUE SOLUTIONS

Buildsafe's highly experienced and professional team offers a specialist service to meet the needs of every project.

A tailored project plan will be established and completed within the determined timeframe. For all your edge protection needs, you need look no further.



1. Riparian Plaza, Brisbane CBD.

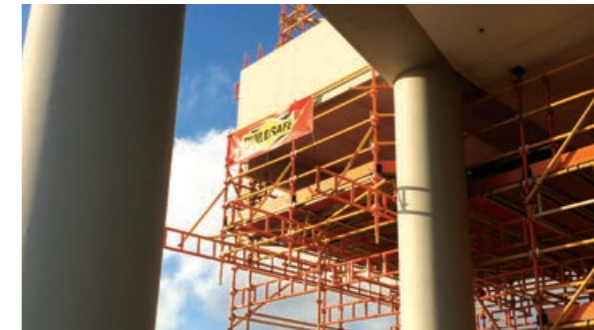

2. Unique solutions.



3. Stock Exchange Hotel, Brisbane CBD.



4. Qantas Hanger, Brisbane Airport.

A WORD FROM THE DIRECTORS

Since the inception of Buildsafe in 2001, our primary focus has remained on being the most respected and sought after height safety provider across many of Australia's major capital cities. As a company, we place strong emphasis on developing and maintaining solid and reliable relationships with our partners and clients.

Today, Buildsafe stands as an innovative leader in the height safety industry. Our company motto, 'Safety Through Innovation', is directly linked to providing efficient and effective height safety solutions by offering a simple, holistic service that compliments the construction process.

We believe that the Buildsafe name immediately communicates our commitment to providing a safe working environment for our clients. Leading the way in edge protection, we set the standard for our competitors to follow.

With a dedicated and highly experienced team of over 600 employees, you can be sure you are in safe hands with Buildsafe.

BUILDSAFE LOCATIONS

VICTORIA

**Keysborough -
Head Office + Branch**

Pakenham

Laverton

Thomastown

Geelong

QUEENSLAND

Arundel - Head Office

North Brisbane

West Brisbane

Gold Coast

Sunshine Coast

Hervey Bay

NEW SOUTH WALES

**Sydney -
Head Office + Branch**

Northern Rivers

Newcastle

Port Macquarie

Nowra

SOUTH AUSTRALIA

Lewiston

BUILDSAFE.NET.AU

1300 558 027



BUILDSAFE.NET.AU